

MaxiFit & MaxiFitXtra Couplings & End Caps

Datasheet

1/2

Coupling

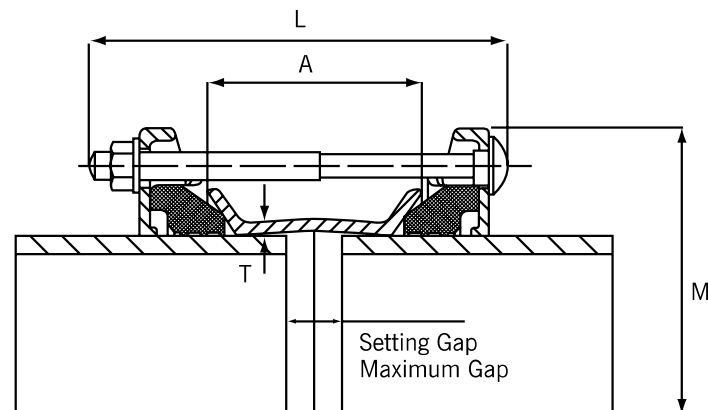

MaxiFit Couplings - Standard Sleeve & End Caps

Nominal Size (mm)	Size Range (mm)		Diameter (mm) M	Overall Length (mm) L	Sleeve Length x Thickness (A) x (T)	Setting Gap (mm)		Bolts No.-Dia x Length	Gasket Mould No.	Weight (kg)	MaxiCap Available	Maximum Threaded Outlet	MaxiFit Plus Available
	Min	Max				Min	Max						
DN40	47.9	59.5	149.5	190.0	100.0 x 4.5	20.0	40.0	2-M12 x 180	1637	3.1			
DN50	57.0	74.0	154.5	190.0	95.0 x 4.5	20.0	40.0	4-M12 x 180	12392/1	3.0	✓	1"	✓
DN65	63.0	85.0	173.5	190.0	95.0 x 4.5	20.0	40.0	4-M12 x 180	12392/2	3.6	✓	1"	✓
DN80	85.0	107.0	195.5	190.0	95.0 x 4.5	20.0	40.0	4-M12 x 180	12392/3	4.1	✓	2"	✓
DN100	107.0	132.0	224.5	190.0	95.0 x 4.5	20.0	40.0	4-M12 x 180	12392/4	5.0	✓	2"	✓
DN125	132.0	158.0	254.5	190.0	95.0 x 5.0	20.0	40.0	4-M12 x 180	12392/6	6.1	✓	2"	✓
DN150	158.0	184.0	280.5	190.0	95.0 x 5.0	20.0	40.0	4-M12 x 180	12392/7	7.0	✓	2"	✓
DN175	189.0	212.0	306.5	230.0	130.0 x 5.0	25.0	50.0	4-M12 x 220	12392/9	9.4	✓	2"	
DN200	218.0	244.0	342.5	230.0	130.0 x 5.0	25.0	50.0	4-M12 x 220	12392/10	10.9	✓	2"	
DN225	243.0	269.0	367.5	230.0	130.0 x 5.0	25.0	50.0	6-M12 x 220	12392/11	12.4	✓	2"	
DN250	266.0	295.0	399.5	230.0	130.0 x 5.0	25.0	50.0	6-M12 x 220	12392/12	14.6	✓	2"	
DN300	315.0	349.0	462.5	230.0	130.0 x 5.0	25.0	50.0	8-M12 x 220	12392/14	19.4	✓	2"	

MaxiFitXtra Couplings - Long Sleeve & End Caps

Nominal Size (mm)	Size Range (mm)		Diameter (mm) M	Overall Length (mm) L	Sleeve Length x Thickness (A) x (T)	Setting Gap (mm)		Bolts No.-Dia x Length	Gasket Mould No.	Weight (kg)	MaxiCap Available	Maximum Threaded Outlet
	Min	Max				Min	Max					
DN50	57.0	74.0	154.5	285.0	200.0 x 5.5	20.0	140.0	4-M12 x 275	12392/1	4.6	✓	1"
DN65	63.0	85.0	173.5	285.0	190.0 x 5.5	20.0	130.0	4-M12 x 275	12392/2	5.2	✓	1"
DN80	85.0	107.0	195.5	285.0	200.0 x 5.5	20.0	140.0	4-M12 x 275	12392/3	6.3	✓	2"
DN100	107.0	132.0	224.5	285.0	190.0 x 5.5	20.0	130.0	4-M12 x 275	12392/4	7.2	✓	2"
DN125	132.0	158.0	254.5	285.0	190.0 x 6.0	20.0	130.0	4-M12 x 275	12392/6	9.0	✓	2"
DN150	158.0	184.0	280.5	285.0	190.0 x 6.0	20.0	130.0	4-M12 x 275	12392/7	10.3	✓	2"
DN175	189.0	212.0	306.5	285.0	190.0 x 6.0	25.0	110.0	4-M12 x 275	12392/9	12.1	✓	2"
DN200	218.0	244.0	342.5	285.0	190.0 x 6.0	25.0	110.0	4-M12 x 275	12392/10	14.1	✓	2"
DN225	243.0	269.0	367.5	350.0	250.0 x 6.0	25.0	165.0	6-M12 x 340	12392/11	18.6	✓	2"
DN250	266.0	295.0	399.5	350.0	250.0 x 6.0	25.0	165.0	6-M12 x 340	12392/12	21.4	✓	2"
DN300	315.0	349.0	462.5	350.0	240.0 x 6.0	25.0	155.0	8-M12 x 340	12392/14	27.0	✓	2"

Every effort has been made to ensure that the information contained in this publication is accurate at the time of publishing. Crane Ltd assumes no responsibility or liability for typographical errors or omissions or for any misinterpretation of the information within the publication and reserves the right to change without notice.

DR0650_03_2020_ISSUE 6

MaxiFit & MaxiFitXtra Couplings & End Caps

Datasheet

2/2

Technical Information

Working Pressure Rating

Water 16 bar

Gas 6 bar

Vacuum Pressure

Capable of accommodating a vacuum pressure of -0.7 bar

Site Test Pressure

1.5 times working pressure for short duration (2 hours)

Angularity

Couplings 6°

The above are for when the product is on maximum pipe outside diameters; can achieve larger ones with smaller pipe diameters.

Bolt Torque/Spanner

M12; Torque 55-65Nm on every bolt

Spanner size A/F 19mm

Temperature Rating of Product

EPDM -20°C to +90°C

Nitrile -20°C to +90°C

For use on applications with fluctuating and / or elevated temperatures (> 60°C) may require regular maintenance to re-tighten the bolts and must be included in any maintenance schedule.

End Load Due to Internal Pressure

MaxiFit DOES NOT resist end load due to the internal pressure - adequate external restraint must be provided to prevent pipe pull out.

Approvals

The following water contact materials used in MaxiFit are approved for use with potable water:-

Rilsan Nylon 11:

- WRAS, AS/NZS 4020, DVGW, W270, ACS & KIWA

EPDM Gaskets:

- WRAS, AS/NZS 4020

In addition to the above, MaxiFit range as a finished product has KIWA certification verifying that the above products comply with the requirements of the Water Supply (Water Fittings) Regulations for England and Wales 1999, the Water Byelaws 2000, Scotland and the Water Regulations Northern Ireland.

DN40 to DN300 MaxiFit has been independently tested by BSI to confirm it meets the requirements of BS EN 14525 (VC 669122)

Materials & Relevant Standards

End Ring, Adaptor Body/Centre Sleeve and End Cap

Ductile Iron to BS EN 1563 Symbol EN GJS-450-10

Gasket

EPDM compound Grade E to BS EN 681-1, Type WA, WC

Nitrile compound to Grade G BS EN 682, Type G

Coating

Sleeve & End Ring:

- Rilsan Nylon 11 to WIS 4-52-01 Part 1

Bolts & Nuts:

- Sheraplex to WIS 4-52-03

Tee Bolts/Bolts

Steel to BS EN ISO 898-1 Property Class 4.8

Bolts

Standard - Steel to BS EN ISO 898-1: property class 4.8

Option - Stainless Steel to BS EN ISO 3506-1: grade A4 property class 50

Nuts

Standard - Steel to BS EN 4190 Grade 4

Option - Stainless Steel to BS EN ISO 3506-2: grade A4 property class 8

Washers

Stainless Steel to BS 1449:Part 2 Grade 304 S15